

Fig No: FPC-800

1/2"~ 2" DN15 ~ DN50

Features :

800Lb Forged steel check valves are available in two bonnet designs. The first design is the Bolted Bonnet, With male-female joint, spiral wound gasket, made in F304L/graphite. Ring joint gasket are also available on request. The second design is the welded bonnet, with a threaded and seal welded joint, On request a full penetration strength welded joint is available.

Check valve Design Construciton and Specifications :

Check vales conform to MSS-SP-118 and ASME B16.34.
 Each are tested according to API598
 Marking is per MSS SP-25.

Construciton is as follows :

- Full Port or Conventional Port
- Piston check
- Spring available on request
- Bolted bonnet with spiral-wound gasket, threaded and seal welded bonnet or threaded and pressure seal bonnet
- Socket weld Ends to ASME B16.11
- Screwed Ends (NPT) to ANSI/ASME B1.20.1

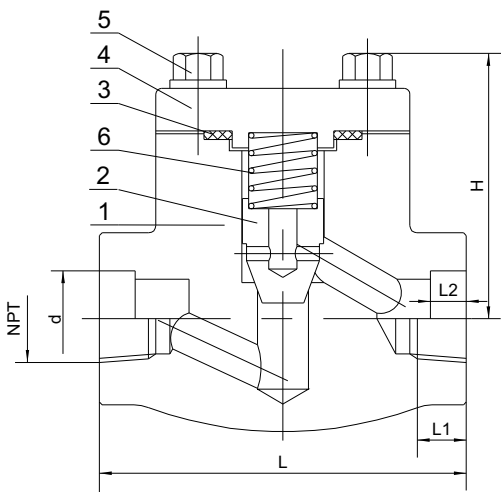

DIMENSIONS

unit:mm

NPS	d	L2	NPT	L1	L	H
1/2	21.8	10	1/2	15	76	76
3/4	27	13	3/4	18	92	92
1	34	13	1	18	106	106
1-1/4	42.5	13	1-1/4	19	120	120
1-1/2	48.5	13	1-1/2	19	140	140
2	61	16	2	25	144	144

MATERIALS LIST

NO	Name	MATERIAL		
1	BODY(SEAT)	A105+ER410	F304(L)	F316(L)
2	PISTON DISC	A182 F6	F304(L)	F316(L)
3	GASKET	F304+GRAPHITE	F316+GRAPHITE	
4	BONNET	A105	F304(L)	F316(L)
5	BOLT	A193 B7	A193 B8	
6	SPRING	F304	F316	

Other Materials Also Available On Requested