

**Fig No:SF-1500 2"~24"**  
**DN50~DN600**

**Features:**

- Swing type design
- Bolted Bonnet
- Body and Bonnet joint accurately machined, Full enclosed gasket
- Disc-Robust one-piece construction to withstand the severe shock of check valve service
- Disc assembly-All parts are accessible from top for easy servicing
- Seat face stellite, ground and lapped to a mirror finish

**Sample Castings:**

Before castings are released for production, the Modentic NDE inspector level, evaluates and approves the submitted x-ray films (100% coverage) as per ASME B16.34 acceptance standard. Improves the internal integrity of castings (RT level 2 or better) at pattern approval.

**Standard compliance:**

- Valve design according to API 600, BS 1868
- Shell wall Thickness according to API 600, BS 1868 class 1500
- Pressure-temperature rating according to ASME/ANSI B16.34
- Material according to ASTM
- End to end according to ASME/ANSI B16.10 class 1500 BW
- Butt weld dimension according to ASME/ANSI B16.25
- Pressure testing according to API 598

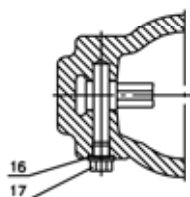
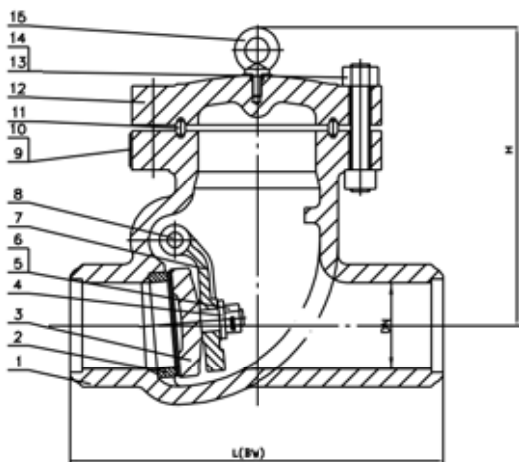

**DIMENSIONS**

unit:mm

SIZE	DN	L(BW)	H
2"	50	368	310
2.5"	65	419	310
3"	80	470	330
4"	100	546	355
6"	150	705	400
8"	200	832	530
10"	250	991	560
12"	300	1130	650
14"	350	1257	710
16"	400	1384	780
18"	450	1537	850
20"	500	1664	980
24"	600	1943	1158

**MATERIAL LIST**

NO	Part Name	Material
1	Body	A216-WCB
2	Seat Ring	A105+STL
3	Disc	A216-WCB+410
4	Washer	STAINLESS STEEL
5	Disc NUT	A276-420
6	Disc Pin	A276-410
7	Hinge	A216-WCB
8	Pin	A276-410
9	Nameplate	STAINLESS STEEL
10	Rivet	STAINLESS STEEL
11	Gasket	Ring Joint-Soft iron
12	Cover	A216-WCB
13	Bolt	A193-B7
14	Nut	A194-2H
15	Lifting Ring	CARBON STEEL
16	Seal Ring	Carbon Steel
17	Plug	A276-410

Other Materials Also Available On Requested