



Stainless Steel I.S.R.S. Y Type Globe Valves , 800 Psi , Screwed End

Fig No: YGB-800 1/4" ~ 2"
DN8 ~ DN50



Features :

- Investment Cast Components
- Inside Screw Rising Stem Design
- Screwed Bonnet , Replaceable Seat Design
- For Food , General Chemical and Industrial Application

Standard Compliance :

- ASTM ASME B16.34 API 598 EN 10213 EN 12516 EN 12266
- ANSI B1.20.1(NPT) ISO 228-1 DIN 2999 BS 21(BSPP)
- BS 21(BSPT) ISO 7-1

Specifications:

- End Connection : Threaded End
- Working Pressure : 800 Psi / 40 Bar (CWP)
- Temperature Range : - 4 to 356 / - 20 to 180
- Pressure Test According to API 598 or EN 12266

MATERIAL LIST

NO	PART NAME	MATERIAL
1	BODY	A351 Gr. CF8M
2	NUT	SS316
3	WASHER	SS316
4	SEAT	SS316
5	DISC	SS316
6	STEM	SS316
7	BONNET	A351 Gr. CF8M
8	GASKET PACKING	PTFE
9	STEM PACKING	PTFE
10	GLAND	SS304
11	GLAND NUT	SS304
12	HANDLEWEEL	ALUMINUM
13	NAME PLATE	ALUMINUM
14	WASHER	SS304
15	HANDLE NUT	SS304

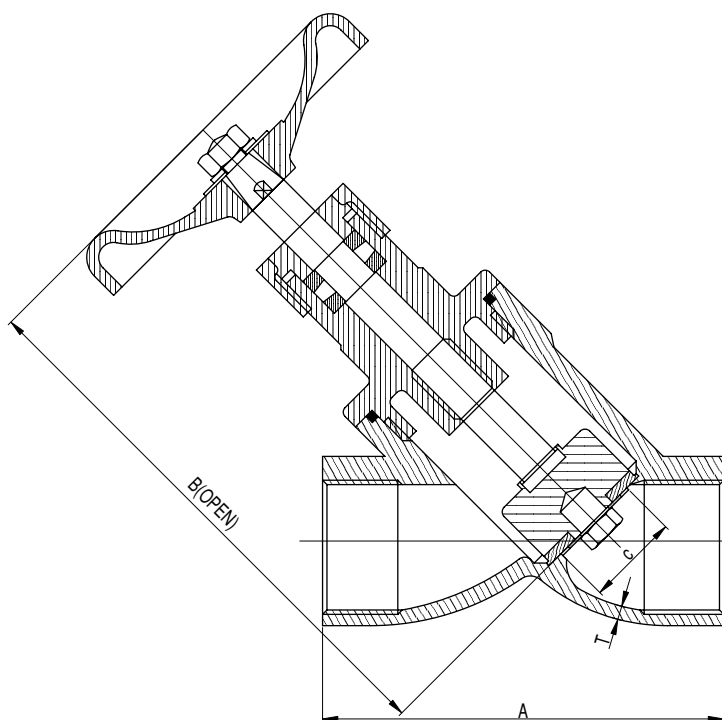

DIMENSION

unit: mm

SIZE	A	B	C	T	
DN8	1/4"	65.0	107.0	11.0	3.0
DN10	3/8"	65.0	107.0	13.0	3.0
DN15	1/2"	65.0	107.0	15.0	3.0
DN20	3/4"	80.0	122.0	20.0	3.2
DN25	1"	90.0	142.0	25.0	3.5
DN32	1-1/4"	105.0	155.0	32.0	3.7
DN40	1-1/2"	120.0	175.0	38.0	4.0
DN50	2"	140.0	195.0	50.0	4.2

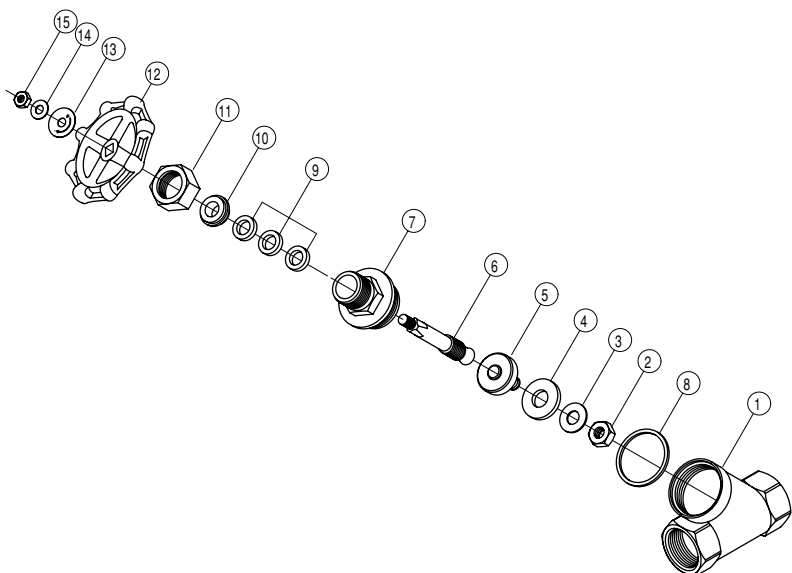

DIMENSION

unit:INCH

SIZE	A	B	C	T	
DN8	1/4"	2.56	4.21	0.43	0.12
DN10	3/8"	2.56	4.21	0.51	0.12
DN15	1/2"	2.56	4.21	0.59	0.12
DN20	3/4"	3.15	4.80	0.79	0.13
DN25	1"	3.54	5.59	0.98	0.14
DN32	1-1/4"	4.13	6.10	1.26	0.15
DN40	1-1/2"	4.72	6.89	1.50	0.16
DN50	2"	5.51	7.68	1.97	0.17