

Fig No:GTF-900 2"~24"
DN50~DN600

Features:

- Flexible wedge
- Seal welded seats
- Outside Screw and Yoke, Rising stem design, Non-rising hand wheel
- Seat face stellite, ground and lapped to a mirror finish
- Universal Trim-13 Cr stem, wedge 13 Cr face and stellite seat API Trim 8 suitable for applications up to 850°F (454°C)
- Body and Bonnet joint accurately machined, Full enclosed gasket

Sample Castings:

Before castings are released for production, the Modentic NDE inspector level evaluates and approves the submitted x-ray films (100% coverage) as per ASME B16.34 acceptance standard
Improves the internal integrity of castings (RT level 2 or better) at pattern approval

Standard compliance:

- Valve design according to API 600
- Shell wall Thickness according to API 600
- Pressure-temperature rating according to ASME/ANSI B16.34
- Material according to ASTM
- Face to Face according to ASME/ANSI B16.10 class 900 RF
- End to end according to ASME/ANSI B16.10 class 900 BW
- Flanged dimension according to ASME/ANSI B16.5 class 900 RF, Finish 125-250 AARH
- Butt weld dimension according to ASME/ANSI B16.25
- Pressure testing according to API 598

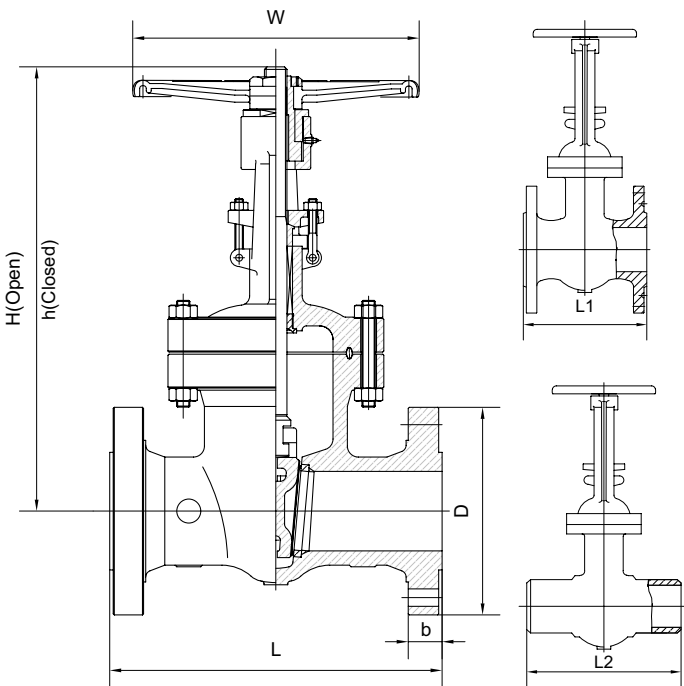

DIMENSIONS

unit:mm

NOM SIZE	L/L2	L1	D	b	H	W
	RF/BW	RTJ			Open	
2"	368.0	371.0	215.9	38.1	620.0	300.0
2-1/2"	419.0	422.0	244.5	41.3	705.0	350.0
3"	381.0	384.0	241.3	38.1	695.0	350.0
4"	457.0	460.0	292.1	44.4	825.0	400.0
6"	610.0	613.0	381.0	55.6	1065.0	*
8"	737.0	740.0	469.9	63.5	1320.0	*
10"	838.0	841.0	546.1	69.8	1540.0	*
12"	965.0	968.0	609.6	79.4	1840.0	*
14"	1029.0	1038.0	641.2	85.7	2025.0	*
16"	1130.0	1140.0	704.8	88.9	2170.0	*
18"	1219.0	1232.0	787.4	101.6	2232.0	*
20"	1320.0	1334.0	857.2	107.9	2435.0	*
24"	1549.0	1563.0	1041.4	140.0	2865.0	*

*Gear Operated

MATERIAL LIST

PART NAME	ASTM Specifications (Specs.-Grades/Types)			
Handwheel Nut	Carbon Steel			
Handwheel	Malleable Iron			
Stem Nut	ASTM A439 GR.D2			
Stem	13CR,316 OR 304,17-4HP,Monel			
Gland Flange	A216-WCB	A352-LCC	A217-WC6	A217-C5
Gland	13Cr.316 OR 304			
Stem Packing	Braided Graphite & Die Formed Graphite Ring			
Backseat Bushing	13Cr.316 OR 304			
Bonnet	A216-WCB	A352-LCC	A217-WC6	A217-C5
Bonnet Gasket	Ring Joint-Soft iron			
Bonnet Bolts and Nuts	A193-B7/A194-2H	A320-L7M/A194-7M	A193-B16/A194-7	A193-B16/A194-7
Gate	A216-WCB	A352-LCC	A217-WC6	A217-C5
Seat Ring	A105,LF2,316 OR 304			
Body	A216-WCB	A352-LCC	A217-WC6	A217-C5
Gland Eye Bolts and Nuts	A193-B7/A194-2H	A320-L7M/A194-7M	A193-B7/A194-2H	
Pin	Carbon Steel			
Grease Nipple	Carbon Steel			
Retaining Nut	Carbon Steel			

Other Materials Also Available On Requested