

FEATURES

- Investment Cast Body Construction
- 2 Pieces Body Design
- ISO 5211 Mounting Flange
- Blow-Out-Proof Stem Design
- Anti-Static Device
- Available for Pneumatic or Electric Actuator
- NACE MR0175 is available upon request
- Super Alloy materials for highly corrosive medium are available upon request

AUTOMATION AVAILABLE

SPECIFICATIONS

- Size Range: DN15 ~ DN150 (1/2" ~ 6")
- End Connection: Flanged End, RF
- Working Pressure: 1.4408 PN40- 38.8 Bar at RT.
1.0619 PN40- 39.0 Bar at RT.
- Steam Pressure: 150 PSIG. Saturated Steam for RTFE.
- Temperature Range: -4 to 356 °F (-20 to 180 °C) for RTFE.

STANDARDS

- Design: EN 12516-1/2 / API 608
- Mounting Flange: ISO 5211
- Face to Face: DIN 3202 F4 for DN15 ~ DN100
DIN 3202 F5 for DN125 ~ DN150
- Flange Dimension: PN40 EN1092-1
- Material: EN1503-1
- Pressure Testing: EN 12266

CERTIFICATE

- Fire Safe: API 607 6th Edition / ISO 10497
- Fugitive Emission: ISO 15848-1
- Quality Assurance: ISO 9001
- Material Certificate: EN 10204-3.1 MTR
- CE Approval: PED 2014/68/EU Module H

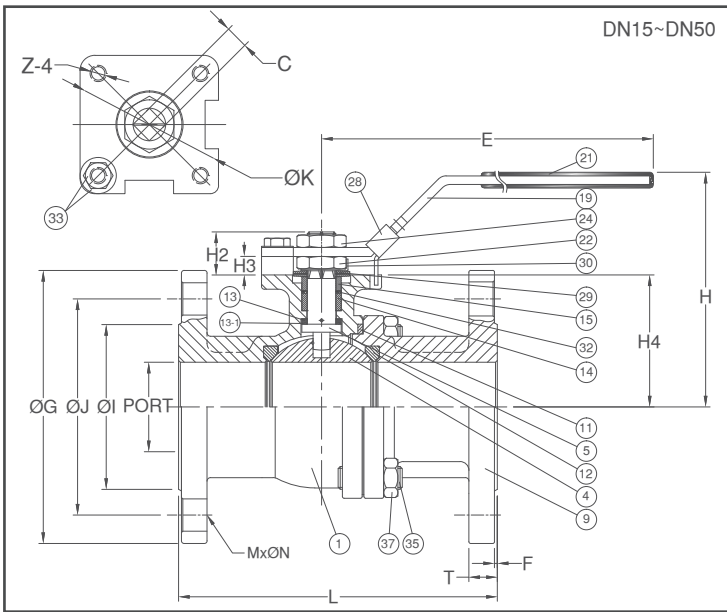

MATERIAL LIST

NO.	PART NAME	MATERIAL (more options available)	
1	BODY	EN1503-1 1.4408	EN1503-1 1.0619
4	BALL	ASTM A351 Gr.CF8M	
5	STEM	ASTM A276 Gr.SS316	
9	END CAP	EN1503-1 1.4408	EN1503-1 1.0619
11	BODY SEAL	GRAPHITE	
12	SEAT	RTFE.(15%G.F.)	
13	THRUST WASHER	GRAPHITE	
13-1	THRUST WASHER	RTFE.(15%G.F.)	
14	STEM PACKING	GRAPHITE	
15	GLAND BUSH	SS304	
19	HANDLE	STEEL	
21	HANDLE COVER	PLASTIC	
22	STEM NUT	SS304	
24	HANDLE NUT	SS304	
28	LOCKING DEVICE	SS304	
29	BELLEVILLE WASHER	SS301	
30	TAB WASHER	SS304	
32	PACKING FOLLOWER	RTFE.(15%G.F.)	
33	STOP PIN SET	SS304	
35	BODY BOLT	ASTM A193 Gr.B8	ASTM A193 Gr.B7
37	BOLT NUT	ASTM A194 Gr.8	ASTM A193 Gr.2H

DIMENSION

SIZE	PORT	unit : mm																
		L	E	H	H2	H3	H4	C	ØG	ØJ	ØI	T	F	MxØN	ØK	Z		
DN15	1/2"	15.0	115.0	132	80.0	16.0	8.0	38.5	9	95.0	65.0	45.0	16	2.0	4xØ14	42/F04	M5x0.8P	
DN20	3/4"	20.0	120.0	132	84.5	15.0	6.5	42.5	9	105.0	75.0	58.0	18	2.0	4xØ14	42/F04	M5x0.8P	
DN25	1"	25.0	125.0	166	102.0	19.0	9.5	52.0	11	115.0	85.0	68.0	18	2.0	4xØ14	50/F05	M6x1.0P	
DN32	1-1/4"	32.0	130.0	166	105.0	19.0	9.5	56.0	11	140.0	100.0	78.0	18	2.0	4xØ18	50/F05	M6x1.0P	
DN40	1-1/2"	38.0	140.0	203	125.0	22.0	13.0	65.3	14	150.0	110.0	88.0	18	3.0	4xØ18	70/F07	M8x1.25P	
DN50	2"	50.0	150.0	203	132.0	22.5	13.0	73.8	14	165.0	125.0	102.0	20	3.0	4xØ18	70/F07	M8x1.25P	

DIMENSION

SIZE	PORT	unit : inch																
		L	E	H	H2	H3	H4	C	ØG	ØJ	ØI	T	F	MxØN	ØK	Z		
DN15	1/2"	0.59	4.53	5.20	3.15	0.63	0.32	1.52	0.35	3.74	2.56	1.77	0.63	0.08	4xØ0.55	1.65/F04	M5x0.8P	
DN20	3/4"	0.79	4.72	5.20	3.33	0.59	0.26	1.67	0.35	4.13	2.95	2.28	0.71	0.08	4xØ0.55	1.65/F04	M5x0.8P	
DN25	1"	0.98	4.92	6.54	4.02	0.75	0.37	2.05	0.43	4.53	3.35	2.68	0.71	0.08	4xØ0.55	1.97/F05	M6x1.0P	
DN32	1-1/4"	1.26	5.12	6.54	4.13	0.75	0.37	2.20	0.43	5.51	3.94	3.07	0.71	0.08	4xØ0.71	1.97/F05	M6x1.0P	
DN40	1-1/2"	1.50	5.51	7.99	4.92	0.87	0.51	2.57	0.55	5.91	4.33	3.46	0.71	0.12	4xØ0.71	2.76/F07	M8x1.25P	
DN50	2"	1.97	5.91	7.99	5.20	0.89	0.51	2.90	0.55	6.50	4.92	4.02	0.79	0.12	4xØ0.71	2.76/F07	M8x1.25P	

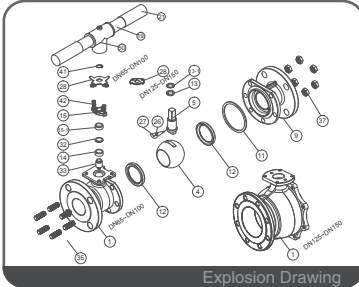
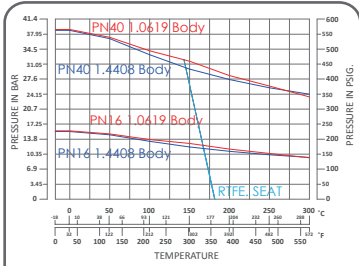

FEATURES

- Investment Cast Body Construction
- 2 Pieces Body Design
- ISO 5211 Mounting Flange
- Blow-Out-Proof Stem Design
- Anti-Static Device
- Available for Pneumatic or Electric Actuator
- NACE MR0175 is available upon request
- Super Alloy materials for highly corrosive medium are available upon request

AUTOMATION AVAILABLE

SPECIFICATIONS

- Size Range DN15 ~ DN150 (1/2" ~ 6")
- End Connection Flanged End, RF
- Working Pressure 1.4408 PN40- 38.8 Bar at RT.
1.0619 PN40- 39.0 Bar at RT.
- Steam Pressure 150 PSIG. Saturated Steam for RTFE.
- Temperature Range -4 to 356 °F (-20 to 180 °C) for RTFE.

STANDARDS

- Design EN 12516-1/2 / API 608
- Mounting Flange ISO 5211
- Face to Face DIN 3202 F4 for DN15 ~ DN100
DIN 3202 F5 for DN125 ~ DN150
- Flange Dimension PN40 EN1092-1
- Material EN1503-1
- Pressure Testing EN 12266

CERTIFICATE

- Fire Safe API 607 6th Edition / ISO 10497
- Fugitive Emission ISO 15848-1
- Quality Assurance ISO 9001
- Material Certificate EN 10204-3.1 MTR
- CE Approval PED 2014/68/EU Module H

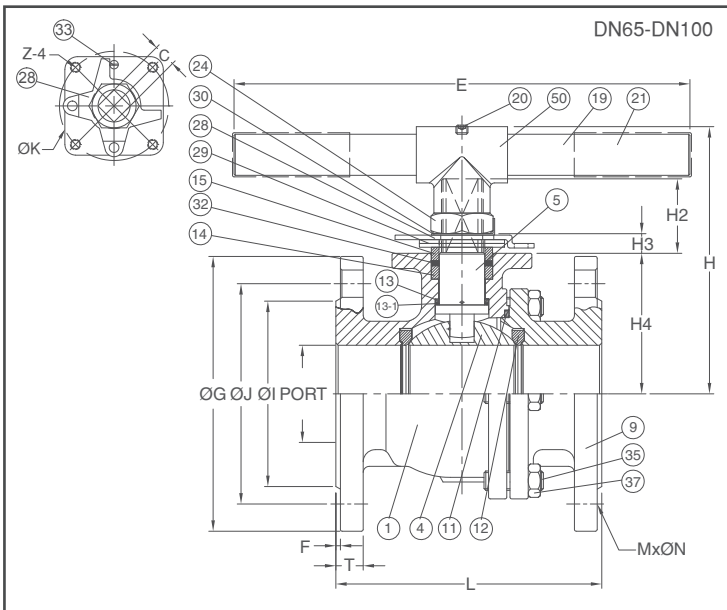

MATERIAL LIST

NO.	PART NAME	MATERIAL (more options available)	
1	BODY	EN1503-1 1.4408	EN1503-1 1.0619
4	BALL	ASTM A351 Gr.CF8M	
5	STEM	ASTM A276 Gr.316	
9	END CAP	EN1503-1 1.4408	EN1503-1 1.0619
11	BODY SEAL	GRAPHITE	
12	SEAT	RTFE.(15%G.F.)	
13	THRUST WASHER	GRAPHITE	
13-1	THRUST WASHER	RTFE.(15%G.F.)	
14	STEM PACKING	GRAPHITE	
15	GLAND BUSH	SS304	
19	HANDLE	STEEL	
20	SET BOLT	SS304	
21	HANDLE COVER	PLASTIC	
24	HANDLE NUT	SS304	
28	STOP PLATE	SS304	
29	BELLEVILLE WASHER	SS301	
30	TAB WASHER	SS304	
32	PACKING FOLLOWER	RTFE.(15%G.F.)	
33	STOP PIN	SS304	
35	BODY BOLT	ASTM A193 Gr.B8	ASTM A193 Gr.B7
37	BOLT NUT	ASTM A194 Gr.8	ASTM A194 Gr.2H
50	HANDLE ADAPTER	ASTM A351 Gr.CF8	

DIMENSION

		unit : mm															
SIZE	PORT	L	E	H1	H2	H3	H4	C	ØG	ØJ	ØI	T	F	MxØN	ØK	Z	
DN65	2-1/2"	64.0	170	300	178	50.0	27.5	92.5	17	185.0	145.0	122.0	22	2.0	8xØ18	102/F10	M10x1.5P
DN80	3"	76.0	180	300	188	50.0	27.5	101.7	17	200.0	160.0	138.0	24	2.0	8xØ18	102/F10	M10x1.5P
DN100	4"	100.0	190	450	202	47.5	28.0	119.0	17	235.0	190.0	162.0	24	2.0	8xØ22	102/F10	M10x1.5P

DIMENSION

		unit : inch															
SIZE	PORT	L	E	H1	H2	H3	H4	C	ØG	ØJ	ØI	T	F	MxØN	ØK	Z	
DN65	2-1/2"	2.52	6.69	11.81	7.01	1.97	1.08	3.64	0.67	7.28	5.71	4.80	0.87	0.08	8xØ0.71	4.02/F10	M10x1.5P
DN80	3"	2.99	7.09	11.81	7.40	1.97	1.08	4.00	0.67	7.87	6.30	5.43	0.94	0.08	8xØ0.71	4.02/F10	M10x1.5P
DN100	4"	3.94	7.48	17.72	7.95	1.87	1.10	4.69	0.67	9.25	7.48	6.38	0.94	0.08	8xØ0.87	4.02/F10	M10x1.5P

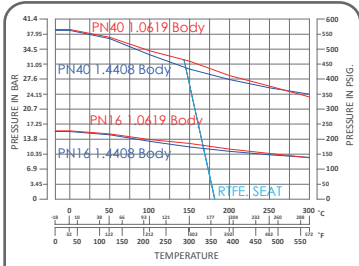

PN40 P-T Chart

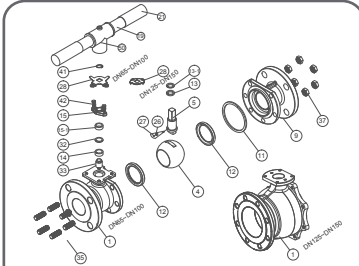

Explosion Drawing

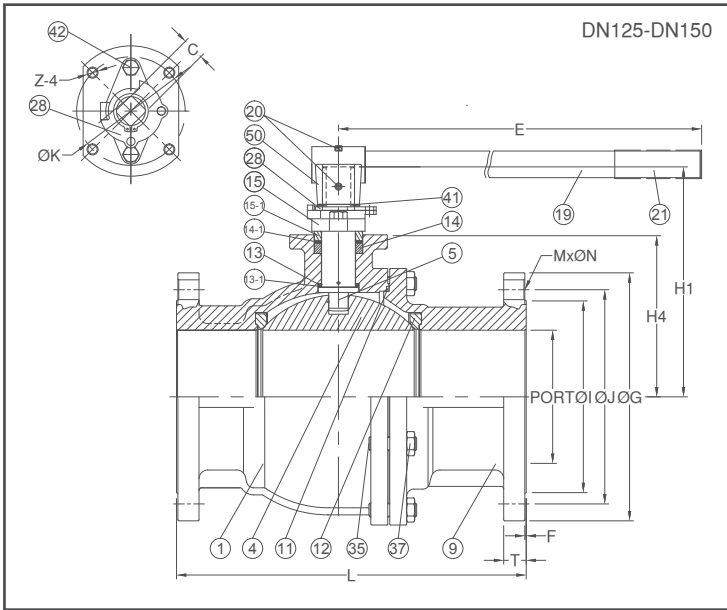

DN125-DN150

FEATURES

- Investment Cast Body Construction
- 2 Pieces Body Design
- ISO 5211 Mounting Flange
- Blow-Out-Proof Stem Design
- Anti-Static Device
- Available for Pneumatic or Electric Actuator
- NACE MR0175 is available upon request
- Super Alloy materials for highly corrosive medium are available upon request

AUTOMATION AVAILABLE

SPECIFICATIONS

- Size Range: DN15 ~ DN150 (1/2" ~ 6")
- End Connection: Flanged End, RF
- Working Pressure: 1.4408 PN40- 38.8 Bar at RT.
1.0619 PN40- 39.0 Bar at RT.
- Steam Pressure: 150 PSIG. Saturated Steam for RTFE.
- Temperature Range: -4 to 356 °F (-20 to 180 °C) for RTFE.

STANDARDS

- Design: EN 12516-1/2 / API 608
- Mounting Flange: ISO 5211
- Face to Face: DIN 3202 F4 for DN15 ~ DN100
DIN 3202 F5 for DN125 ~ DN150
- Flange Dimension: PN40 EN1092-1
- Material: EN1503-1
- Pressure Testing: EN 12266

CERTIFICATE

- Fire Safe: API 607 6th Edition / ISO 10497
- Fugitive Emission: ISO 15848-1
- Quality Assurance: ISO 9001
- Material Certificate: EN 10204-3.1 MTR
- CE Approval: PED 2014/68/EU Module H

MATERIAL LIST

NO.	PART NAME	MATERIAL (more options available)	
1	BODY	EN1503-1 1.4408	EN1503-1 1.0619
4	BALL	ASTM A351 Gr.CF8M	
5	STEM	ASTM A276 Gr.316	
9	END CAP	EN1503-1 1.4408	EN1503-1 1.0619
11	BODY SEAL	GRAPHITE	
12	SEAT	RTFE. (15%G.F.)	
13	THRUST WASHER	GRAPHITE	
13-1	THRUST WASHER	RTFE. (15%G.F.)	
14	STEM PACKING	GRAPHITE	
15	GLAND FLANGE	ASTM A216 Gr.WCB	
15-1	GLAND BUSH	SS304	
19	HANDLE	STEEL	
20	SET BOLT	SS304	
21	HANDLE COVER	PLASTIC	
28	STOP PLATE	SS304	
32	PACKING FOLLOWER	RTFE. (15%G.F.)	
35	BODY BOLT	ASTM A193 Gr.B8	ASTM A193 Gr.B7
37	BOLT NUT	ASTM A194 Gr.8	ASTM A194 Gr.2H
41	SNAP RING	SS304	
42	GLAND BOLT	SS304	
50	HANDLE ADAPTER	ASTM A351 Gr.CF8	

DIMENSION

															unit : mm	
SIZE	PORT	L	E	H1	H4	C	ØG	ØJ	ØI	T	F	MxØN	ØK	Z		
DN125	5"	125.0	325	450	233.0	163.0	23	270.0	220.0	188.0	26	3.0	8xØ26	125/F12 M12x1.75P		
DN150	6"	150.0	350	800	259.0	182.5	23	300.0	250.0	218.0	28	3.0	8xØ26	125/F12 M12x1.75P		

DIMENSION

															unit : inch	
SIZE	PORT	L	E	H1	H4	C	ØG	ØJ	ØI	T	F	MxØN	ØK	Z		
DN125	5"	4.92	12.80	17.72	9.17	6.42	0.91	10.63	8.66	7.40	1.02	0.12	8xØ1.02	4.92/F12 M12x1.75P		
DN150	6"	5.91	13.78	31.50	10.20	7.19	0.91	11.81	9.84	8.58	1.10	0.12	8xØ1.02	4.92/F12 M12x1.75P		