

**Fig No: MD-52 Full Bore**  
**1/2" ~ 6" DN15 ~ DN150**



**Features:**

- Investment Cast Components.
- Blow-Out-Proof Stem Design, Antistatic Device.
- Two Position Locking Device.
- Four Point ISO 5211 Mounting Pad Bolt Circle.
- Cast Bosses For Bleed / Drain Port.
- Available Carbon Or Stainless Body Construction.

**Standards Compliance:**

ASME B16.34	MSS-SP-55
ANSI B16.10	MSS-SP-61
ANSI B16.5	API 598 MSS-SP-72

**Specifications:**

- Temperature range:-4 to 356°F (-20 to 180°C).
- 150 psig saturated steam.
- Face To Face:ANSI B16.10 Class 600
- Flange:ANSI B16.10 Class 600 Flanged Fitting

**MATERIALS LIST**

NO.	PART NAME	MATERIAL
1	BODY	ASTM A351 Gr.CF8M
4	BALL	ASTM A351 Gr.CF8M
5	STEM	SS316
9	END CAP	ASTM A351 Gr.CF8M
11	BODY SEAL	PTFE.
12	SEAT	RTFE.
13	THRUST WASHER	PTFE.
14	STEM PACKING	PTFE.
15	GLAND	SS304
17	STEM BUSHING	PTFE.
19	HANDLE	FCD45
28	STOP PLATE	SS304
35	STUD	ASTM A193 Gr.B8
37	NUT	ASTM A194 Gr.8
41	SNAP RING	SS304
42	GLAND BOLT	SS304
56	GLAND BEARING	PTFE.

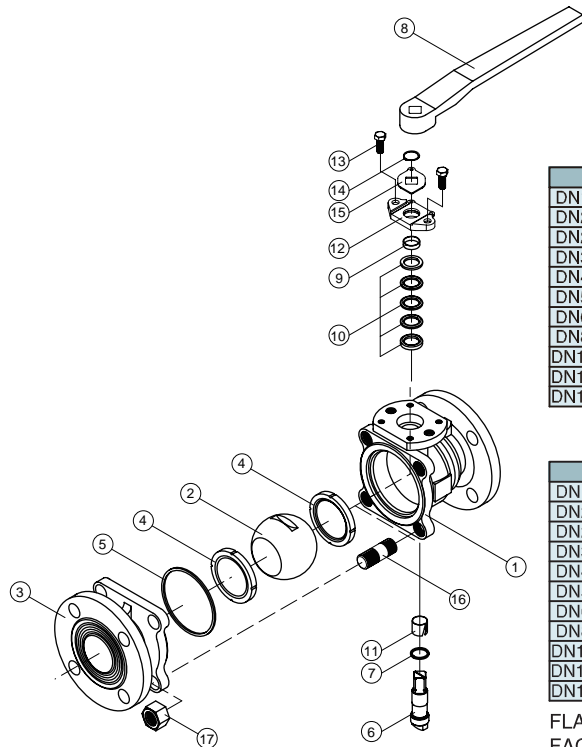
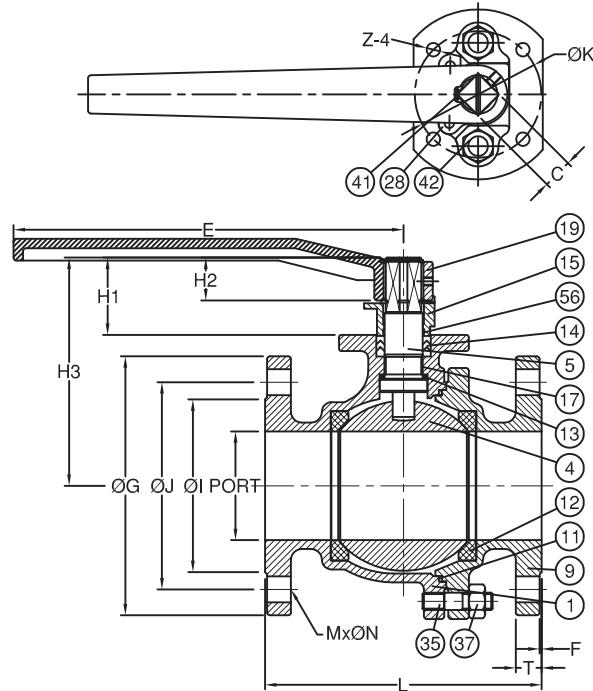

**DIMENSIONS**

unit:mm

SIZE	PORT	L	E	H1	H2	H3	C	ØG	ØJ	ØI	T	F	M	ØN	ØK	Z-4	
DN15	1/2"	15.0	165.0	130.8	22.7	12.5	65.7	11.0	95.3	66.5	35.1	14.2	6.4	4	15.7	42.0	1/4"-20
DN20	3/4"	20.0	190.0	130.8	22.5	12.5	68.2	11.0	117.3	82.6	42.9	15.7	6.4	4	19.1	42.0	1/4"-20
DN25	1"	25.0	216.0	165.0	29.3	15.5	80.6	14.0	124.0	88.9	50.8	17.5	6.4	4	19.1	50.0	1/4"-20
DN32	1-1/4"	32.0	229.0	165.0	29.3	15.5	86.5	14.0	133.4	98.6	63.5	20.6	6.4	4	19.1	50.0	1/4"-20
DN40	1-1/2"	38.0	241.0	202.0	38.4	21.5	108.9	17.0	155.4	114.3	73.2	22.4	6.4	4	22.4	70.0	5/16"-18
DN50	2"	50.0	292.0	202.0	38.4	21.5	116.5	17.0	165.1	127.0	91.9	25.4	6.4	8	19.1	70.0	5/16"-18
DN65	2-1/2"	63.0	330.0	202.0	38.4	21.5	139.0	17.0	190.5	149.4	104.6	28.4	6.4	8	22.4	70.0	5/16"-18
DN80	3"	80.0	356.0	328.5	58.3	31.5	169.4	22.0	209.6	168.1	127.0	31.8	6.4	8	22.4	102.0	3/8"-16
DN100	4"	98.0	432.0	328.5	60.3	33.1	193.3	22.0	273.1	215.9	157.2	38.1	6.4	8	25.4	102.0	3/8"-16
DN125	5"	125.0	508.0	752.5	75.0	45.5	237.0	27.0	330.2	266.7	185.7	44.5	6.4	8	28.4	125.0	1/2"-13
DN150	6"	150.0	558.8	752.5	75.0	45.5	256.0	27.0	355.6	292.1	215.9	47.8	6.4	12	28.4	125.0	1/2"-13

**DIMENSIONS**

unit:inch

SIZE	PORT	L	E	H1	H2	H3	C	ØG	ØJ	ØI	T	F	M	ØN	ØK	Z-4	
DN15	1/2"	0.59	6.50	5.15	0.89	0.49	2.59	0.43	3.75	2.62	1.38	0.56	0.25	4	0.62	1.65	1/4"-20
DN20	3/4"	0.79	7.48	5.15	0.89	0.49	2.69	0.43	4.62	3.25	1.69	0.62	0.25	4	0.75	1.65	1/4"-20
DN25	1"	0.98	8.50	6.50	1.15	0.61	3.17	0.55	4.88	3.50	2.00	0.69	0.25	4	0.75	1.97	1/4"-20
DN32	1-1/4"	1.26	9.02	6.50	1.15	0.61	3.41	0.55	5.25	3.88	2.50	0.81	0.25	4	0.75	1.97	1/4"-20
DN40	1-1/2"	1.50	9.49	7.95	1.51	0.85	4.29	0.67	6.12	4.50	2.88	0.88	0.25	4	0.88	2.76	5/16"-18
DN50	2"	1.97	11.50	7.95	1.51	0.85	4.59	0.67	6.50	5.00	3.62	1.00	0.25	8	0.75	2.76	5/16"-18
DN65	2-1/2"	2.48	12.99	7.95	1.51	0.85	5.47	0.67	7.50	5.88	4.12	1.12	0.25	8	0.88	2.76	5/16"-18
DN80	3"	3.15	14.02	12.93	2.30	1.24	6.67	0.87	8.25	6.62	5.00	1.25	0.25	8	0.88	4.02	3/8"-16
DN100	4"	3.86	17.01	12.93	2.37	1.30	7.61	0.87	10.75	8.50	6.19	1.50	0.25	8	1.00	4.02	3/8"-16
DN125	5"	4.92	20.00	29.63	2.95	1.79	9.33	1.06	13.00	10.50	7.31	1.75	0.25	8	1.12	4.92	1/2"-13
DN150	6"	5.91	22.00	29.63	2.95	1.79	10.08	1.06	14.00	11.50	8.50	1.88	0.25	12	1.12	4.92	1/2"-13

FLANGE DIMENSION: ASME B16.5  
FACE TO FACE: ASME B16.10